

CAD FILE:

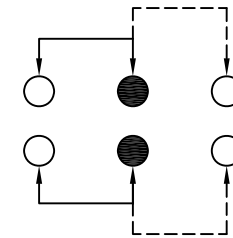

SCHEMATIC ( NON-SHORTING )

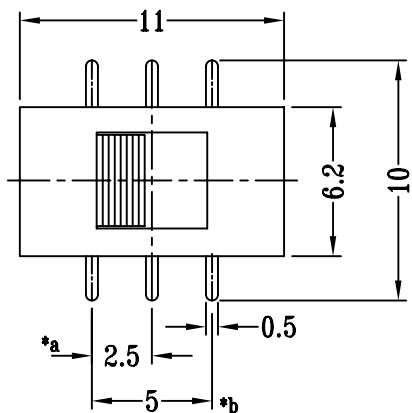
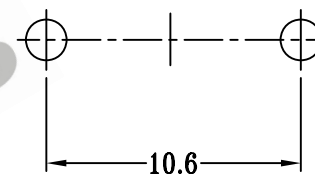
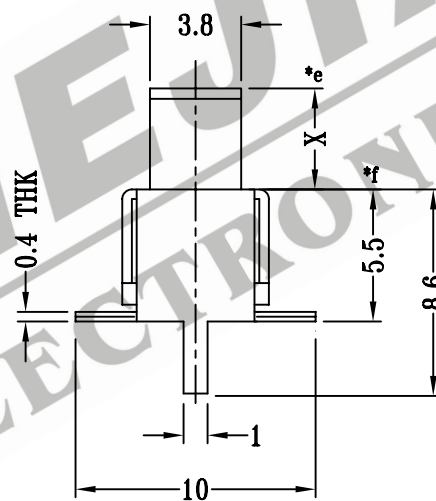
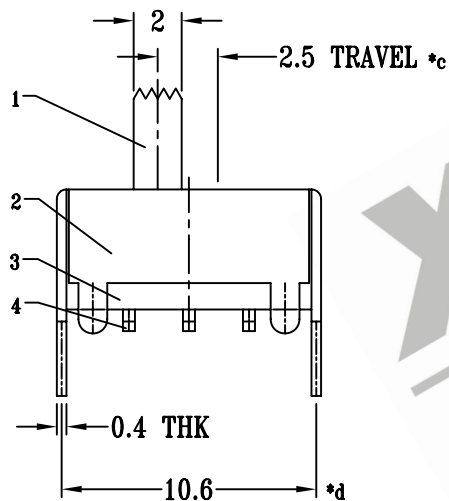

P.C.B LAYOUT

注:带"\*"表示关键尺寸(6个)

				TOLERANCE UNLESS SPECIFIED		SHENZHEN XIEJIA ELECTRONICS CO.,LTD.							
				WITHIN: 1.5±0.1mm		ISSUE		DATE		DESCRIPTIONS		APPD.	
8						TITLE : VERTICAL SLIDE SWITCH				UNIT : MM		DRWG NO.: XJ-DR-SS22E10-00	
7						MODEL: SS-22E10				SCALE: 3:1		DWN. ZHOUYU	2003-6-7
6	SPRING	STEEL WIRE	2	TEMPER		OVER : 1.5±0.2mm				CHK'D FANGYING	2003-6-7		
5	CONTACT CLIP	COPPER STRIP	2	Ag PLATED	ALL MATERIALS MUST BE COMPLIANT TO ROHS				APPD. KANGXINAN	2003-6-7			
4	TERMINAL	BRASS STRIP	6	Ag PLATED OVER Ni PLATED									
3	BASE	PHENOLIC RESIN	1	ORANGE									
2	FRAME	STEEL STRIP	1	Ni PLATED									
1	KNOB	POM	1	BLACK									
NO.	PART NAME	MATERIAL	Q'TY	FINISHING									